



**KOMPTECH**

TECHNOLOGY FOR A BETTER ENVIRONMENT

# TOPTURN X4500

TURNER FOR TRIANGULAR WINDROWS

PERFECT MIXING

WHEEL OR TRACK

ON TOP OF THE SITUATION

MAINTENANCE MADE EASY







## HIGHLIGHTS



- » Large-dimensioned turning drum for high throughput and complete mixing
- » Wheel drive or Track drive
- » Comfortable cabin with a lot of space and new intuitive controls
- » Easy maintenance access with ladders and platforms integrated in the body
- » Wide application area: Composting of MSW, green waste, biowaste, sewage sludge, treatment of contaminated soils, mixing of ores



# TOPTURN X4500

## A NEW ENTRY

The new Topturn X4500 brings high-end performance to the entry level category. As the successor to Topturn 3500, the X4500 packs the proven functionality of the X series in a scale that is a perfect fit for small and medium-size composting operations. A robust frame in a pioneering new design, high performance hydraulics and generously dimensioned drum mean high throughput in all working scenarios.

For small operators with big plans, the X4500 also comes in a more powerful 205 kW version. All engines meet the latest exhaust requirements. Generously dimensioned cooling systems keep them running smoothly even under full load and high ambient temperatures. Further plus points are hydraulically extended maintenance platforms for ready access, and low wear costs through double-use turning blades.

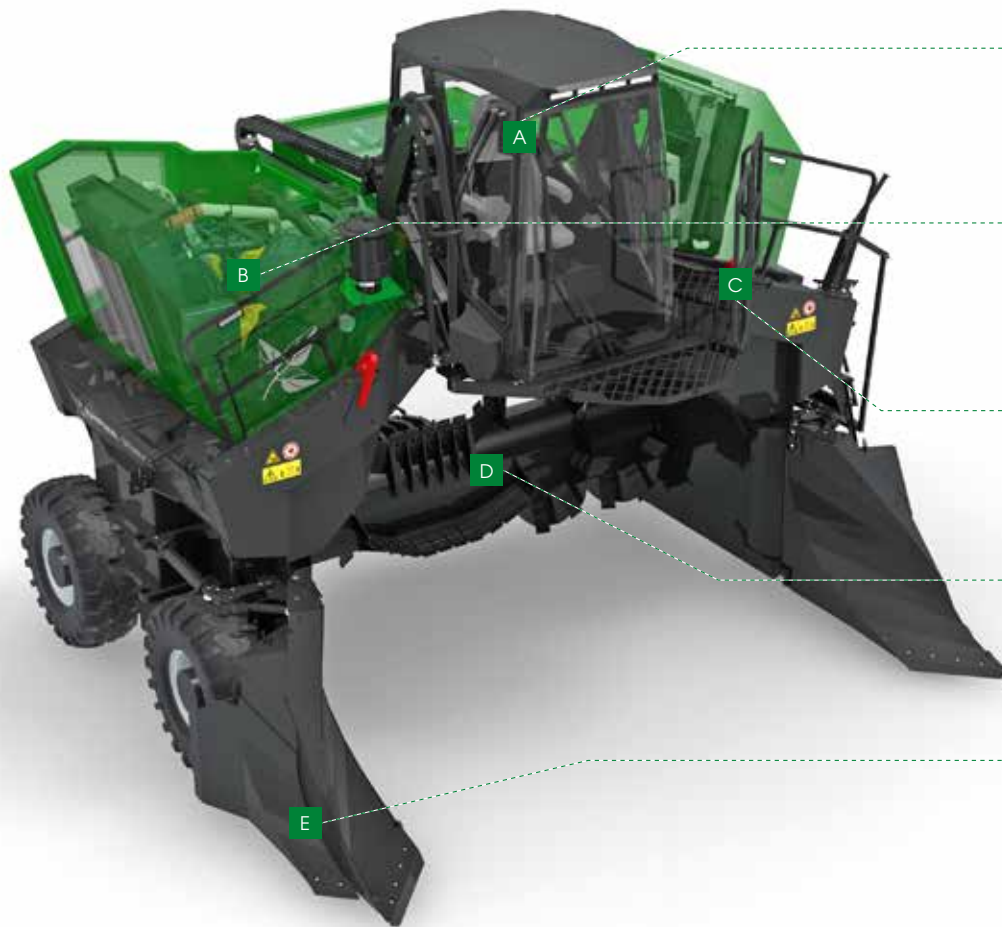

**A**  
Spacious comfortable cabin  
(optional with lift function)

**B**  
Powerful diesel engine in two  
output levels (151/205 kW)

**C**  
Service steps and platform  
simplify maintenance

**D**  
1.2 m diameter drum with  
double-use blades

**E**  
New one-piece plough blades  
(need not be removed for transport)



01

### Wheel or track

No compromises on the chassis - the X4.5 has the same chassis dimensions as the X55. The wheeled chassis provides a high level of traction, quick maneuverability and best driving comfort. The tracked chassis is the ideal option for unpaved ground. The open track design enables simple cleaning.



02

### On top of the situation

The new cabin is a comfortable workspace, with a lot of room, powerful air conditioner and air-cushioned seat. The information system can be intuitively operated using a large colour display, so the machine can be adapted to any working conditions. The optional lift cabin makes access easier and minimizes the effort for converting from working to transport position.



03

### Maintenance made easy

A press of a button turns the left and right body panels into roomy maintenance platforms with convenient access steps so the operator can reach all maintenance points safely and easily. Double-use blades on the drum (180° turnable) keep wear costs low.

## Topturn X4500

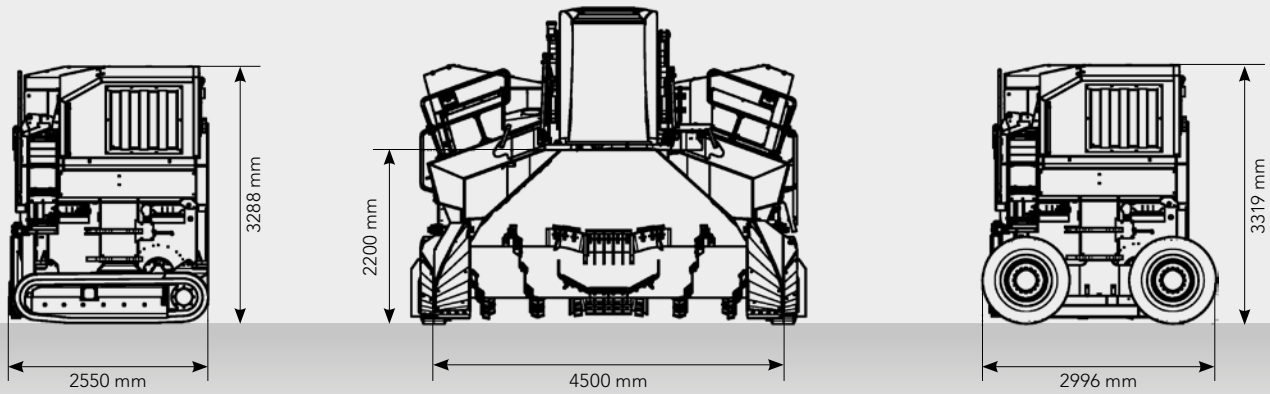

Track transport dimensions

Working position

Wheel transport dimensions

### TOPTURN X4500

<b>Drive</b>	
Diesel engine:	CAT ® C7.1 Tier 4 Final/Stage IV or Tier 3/Stage IIIA
Power (kW / HP):	151/205 or optional 205/278
<b>Turning unit</b>	
Turning drum diameter (mm):	1200
Turning drum rpm:	0-195
<b>Windrow dimensions</b>	
Windrow width (mm):	4500
Max. windrow height (mm):	2200
Windrow cross-section at 45° repose angle (m²):	5.1
<b>Travelling speeds (I standard, II optional)</b>	
Wheel (km/h):	I: 0-4 II: 0-6
Track (km/h):	I: 0-4
<b>Dimensions L x B x H</b>	
Transport dimensions Wheel (mm):	4851 x 2996 x 3319
Transport dimensions Track (mm):	4851 x 2550 x 3288
Working dimensions Wheel (mm):	4484 x 5080 x 3606(+380)
Working dimensions Track (mm):	4126 x 5080 x 3645(+380)
<b>Weight</b>	
Wheel (t):	~ 14.5
Track (t):	~ 15.0
<b>Throughput (dependent on material)</b>	
Throughput performance (m³/h):	up to 3000
<b>Options</b>	

Two speed levels, lift-cabin, central lubrication, scraper, protective ventilation, watering system etc.  
A lateral displacement device is not available.



Komptech GmbH  
Kühau 37, 8130 Frohnleiten, Austria  
[t] +43 3126 505 - 0  
[f] +43 3126 505 - 505  
[e] info@komptech.com

www.komptech.com

We reserve the right to make technical changes in the course of ongoing development. E2016